

4-20mA input interface connects to the HCU

EVC-C 'IN' INTERFACE

- Neg + 24 DC (Engine supply)

blue ARROW Engine Interface Module

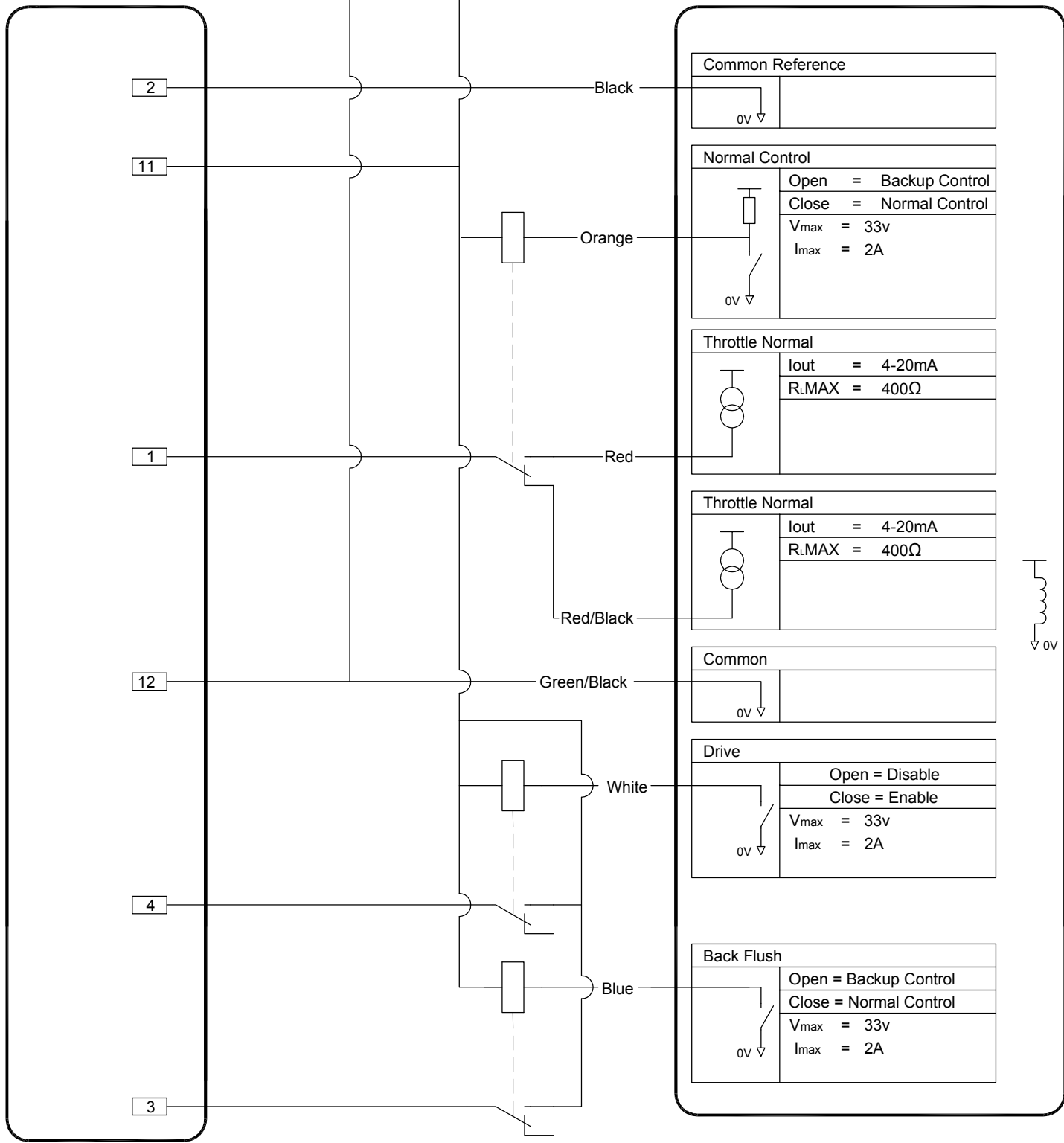

**C. W. F. Hamilton & Co. Ltd Christchurch, New Zealand**

AMENDMENT Issued for production

ECN	CL566	BY	P.W	DATE	13.04.09
JET					

This print is provided on a restricted basis and is not to be used in any way detrimental to the interests of C. W. F. Hamilton Ltd

MATERIAL	Certified	Weight (kg)	UNLIMITED DIMENSIONS TO BE ±0.5
Standard	Approved	Name	Date
Designed	Reviewed	R.L.	02.04.09

DESCRIPTION  
blueARROW ENGINE SCHEMA L3 CONFIGURATION 4-20mA

DWG No 208010 A

Manufacturer	Model	Notes	Normal				Backup
			Demand Type	Feedback Type	Idle RPM	Max RPM	EngDmd Mode
VOLVO	D4, D6, D9, D11, D12, D16	EVC-C	Current	Jet	TBC#	TBC#	Current

Notes  
# Enter values set for particular installation. Adjust to give jet shaft RPM  
Values not specified to be left at factory defaults  
Relays are not in Hamilton's scope of supply

Recommended Relay  
Omron MY4 (Gold Contacts)  
Available from  
Farnell Inone  
\* Base 176-963  
\* Clip: 103-923  
\* MY4 Relay: 186-454  
  
RS  
\* MY4 Relay: 488-2569  
\* Base: 196-6147

